

combiloop CL3 G

FOR HIGH-PERFORMANCE MACHINING UP TO 27 L/MIN
最高 27 L/MIN 的高性能加工



Pure power! Filter finenesses of up to 25 µm and an integrated bypass filtration of the machine tank is no problem thanks to the optional automatic filter. The control pump generates up to 15 °C less heat compared to conventional pumps, and using pressure of up to 300 bar, even smallest bores can be realised.

纯粹动力! 可选用全自动过滤器, 通过集成的过滤系统, 过滤精度可达 25 µm。和传统泵相比, 控制泵的温度最高可降低 15 °C, 并且采用最高 300 bar 的压力, 即便是最小的孔也不在话下。

Technical data // 技术数据



Equipment	// Approx. 1,300 x 600 x 1,100 mm, weight approx. 430 kg // < 300 bar, eco+ self-regulating piston pump, 130 l clean liquid tank, electronic control // Power supply 3~ / PE 400 V / 50 Hz
Flow rate	9 – 27 l/min
Pressure	// 80 bar up to 110 bar max at 27 l/min // 130 bar up to 150 bar max at 20 l/min // 210 bar max. at 12 l/min // 300 bar max. at 9 l/min
Filter / Filter fineness	// Exchangeable filter (fibreglass, 25 µm) // Twin coupling filter (fibreglass, 25 µm) // Automatic filter (30 µm), bypass filter, desludging into wire mesh collector (150 µm)
Operation	// Cutting oil // Water emulsion (min. 8 % oil content)
Service connections	Up to 10 controllable service connections

设备	// 尺寸大约 1,300 x 600 x 1,100 mm, 重量大约 430 kg // 小于 300 bar, 节能 + 自调节活 塞泵, 130 l 洁净液体箱, 电子控件 // 电源 3~ / PE 400 V / 50 Hz
流速	9 – 27 l/min
压力	// 27 l/min 时 80 bar 至 110 bar // 20 l/min 时 130 bar 至 150 bar // 12 l/min 时最大 210 bar // 9 l/min 时最大 300 bar
过滤/ 过滤精度	// 可更换过滤器 (玻璃纤维, 25 µm) // 双耦合过滤器 (玻璃纤维, 25 µm) // 自动过滤器 (30 µm), 旁路过滤器, 疏导至过滤网收集器中 (150 µm)
工作	// 切削油 // 切削液 (至少含 8 % 乳化液)
服务接口	最多 10 个可控制的服务接口

Benefits

- // Latest control technology and simple operation thanks to the touch pad.
- // Simple servicing and maintenance thanks to intelligent space utilisation.
- // Especially high-performance cutting demands pressures above 100 bar.
The routine work here includes deep holes drilled to 2–5 mm and machining operations on hard alloys.

优势

- // 借助触摸板实现最新的控制技术和简便操作。
- // 借助巧妙的空间利用简化维修和维护。
- // 高性能切割, 满足 100 bar 以上的压力需求。日常工作包括钻出达到 2–5 mm 的深孔, 并且可在硬合金上进行加工操作。

combiloop CL3 G

FOR HIGH-PERFORMANCE MACHINING UP TO 27 L/MIN
最高 27 L/MIN 的高性能加工

Function // 功能

- // High pressure: up to 300 bar
- // Flow rate: up to 27 l/min
- // 高压: 最高 300 bar
- // 流速: 最高 27 l/min



Experience one core-innovation behind our compactness – our ingenious filtration!

体验我们紧凑性背后的核心创新 – 我们独创性的过滤!

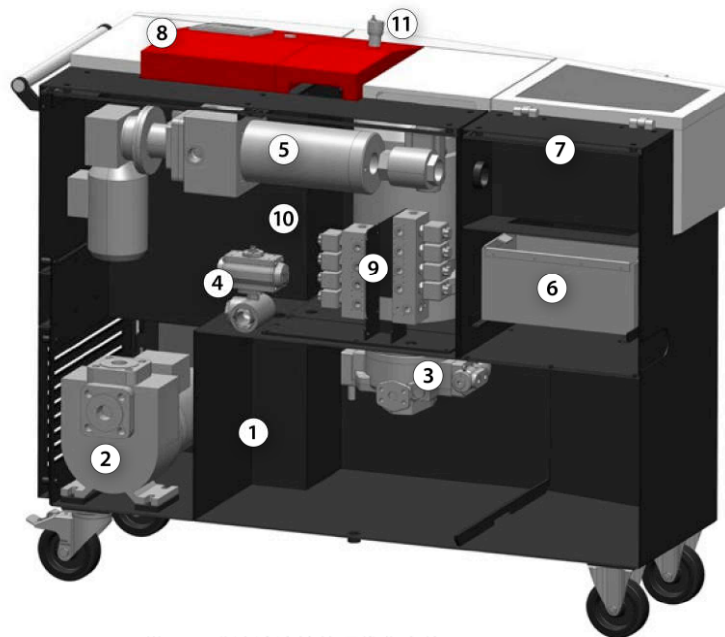

- 1 // Modern housing with 130-liter clean liquid tank
- 2 // Reciprocating pump for filter cycle
- 3 // eco+ self-regulating piston pump technology
- 4 // Ball valve for bypass filtration
- 5 // Self-cleaning automatic filter (option)
- 6 // Wire mesh collector for filter sludge
- 7 // Settling chamber flushing tank
- 8 // Touch panel for system operation
- 9 // Manifold with controllable service connections
- 10 // Electronic control
- 11 // Pressure adjustment

- 1 // 带 130 升清洁液箱的现代化壳体
- 2 // 用于过滤循环的往复泵
- 3 // 节能 + 自调节活塞泵技术
- 4 // 用于旁通过滤的球阀
- 5 // 自清洁自动过滤器 (选件)
- 6 // 用于过滤污泥的丝网收集器
- 7 // 沉降室冲洗箱
- 8 // 用于系统操作的触摸面板
- 9 // 多种可控服务接口
- 10 // 电子控件
- 11 // 压力调节

Fields of application:

Early breaking of chips, spindle flushing, deep hole drilling of up to 0.6 mm and 100xD at the use of gun drills. All chip types. Normal degree of machine contamination. Brass and aluminum should be processed in conjunction with an automatic filter.

应用领域:

更早折断切屑, 主轴冲洗, 使用枪钻直径达0.6mm,可钻出100XD的深孔, 适合所有切屑类型。正常程度的机器污染。应当结合自动过滤器加工黄铜和铝。

Your notes: // 您的注释: